

# Optimization of an Electric Snowmobile for CSC 2013

Ali Najmabadi, Gurdeepak Singh

McGill University

## ABSTRACT

McGill University's 2013 Wendigo prototype returns to the Clean Snowmobile Challenge (CSC) with a new 2011 Ski-Doo MXZ chassis, significant noise reductions, a towing capacity enhancing structure, more available power and a new accumulator to increase the snowmobile's range. All changes made this year will provide researchers at Summit Station, in Greenland, with a higher value snowmobile.

## INTRODUCTION

The Clean Snowmobile competition challenges students to design and build clean snowmobiles for the real market. McGill University participates in the zero-emissions category of the event. The main goal of this category is to design a snowmobile specifically tailored for researchers in zero-emission research zones such as Summit Station in Greenland. The main sled characteristics sought are sufficient range, high towing capacity, affordability, reliability, safety and as little maintenance as possible. In addition, the competition rewards powerful and quiet sleds.

## REVIEW OF 2012 RESULTS

McGill's 2012 snowmobile, built on a 2011 Ski-Doo Tundra chassis, competed reliably in all events. The team was satisfied by its performance and confident it would suit the needs of a researcher in Greenland. In 2013, the team wishes to improve its design to improve performance. To understand where to emphasize

the design, a CSC 2012 point analysis was conducted. The following table illustrates McGill's performance in the dynamic events.

Event	McGill Score	Max Score	Improvement Potential (delta)
Range	100	0	100*
Draw Bar Pull	0	50	50
Noise	38	150	112
Loaded Acceleration	0	50	50
Weight	100	0	0
Handling	0	100	100
MSRP	36.8	50	13.2

**Table 1** - CSC ZE McGill Results Analysis

\*McGill would have been zero had the competitor not been disqualified.

## GOALS AND OBJECTIVES

The McGill Electric Snowmobile Team's (MEST) fundamental design goal is to produce a reliable and affordable electric snowmobile which is easy to convert from a gasoline machine. More specifically, this entails designing an electric powertrain that easily fits inside a stock chassis with as few modifications required, uses reliable, maintenance-free and low cost components while maintaining high safety standards.

Crucially, 600 competition points out of possible 1050 are directly related to range, noise and dynamic performance – acceleration and handling.

By reviewing competition scoring scheme and team's performance in the past competitions, the key areas of improvement and team design goals are:

1. Noise reduction
2. Drag reduction
3. Dynamic performance improvement, particularly handling and power to weight ratio
4. Towing capacity

**CHASSIS SELECTION**

One of the most cost-effective solutions that doesn't compromise snowmobile's handling is the appropriate chassis selection.

Based on the team goals and objectives, the team compared general types of snowmobiles available on the market.

Goal	Utility & long track	Sports & short track
Noise		+
Drag		+
Handling		+
Power/weight		+
Towing capacity	+	

**Table 2** - Comparison of snowmobile types. + indicates advantage.

One of the main sources of noise in an electric snowmobile is the track. A short track is not only quieter, it has less drag which improves the snowmobile's handling and dynamic performance.

Based on this comparison and the team's goals and objectives, the team decided to convert the powertrain of a light weight, performance oriented and short tract snowmobile. Regarding the towing capacity, the 2012 snowmobile was torque limited. Since the 2013 snowmobile's powertrain is similar to last year's and it will use a higher hitch, it's towing capacity is not compromised.

For CSC 2013, the team chose a 2011 Ski-Doo MXZ chassis.



**Figure 1** – 2011 BRP MXZ <sup>1</sup>

This chassis meets all of the team's requirements. Some of the main advantages of this chassis are:

- A low cost chassis
- Short track (less noise and drag)
- Large ski stance for higher stability
- Light weight for maneuverability and dynamic performance
- Cargo space on the tunnel

**RANGE**

The first design aspect that affects the range of any electric vehicle is the battery technology used. The main characteristic that needs to be looked at is the Gravimetric Energy Density (GED). Trivially, a desired energy storage technology has to have a high GED in order to make it a worthwhile energy source. Table 3 compares the Gravimetric energy density and many other characteristics of the three main available vehicle battery technologies.

	Pb-Acid	NiMH	Li-ion
Energy Density (Gravimetric)(Wh/kg)	60	125	240
Energy Density (Volumetric)(Wh/L)	100	400	550
Electrochemical potential difference (Volts)	1.5	1.2	3.6

**Table 3** – Battery chemistry comparison <sup>2</sup>

Clearly, Lithium-ion is an ideal choice for better range. However, even though a battery with high GED, like Lithium-ion, would improve the range, it should be compared to other battery technologies in terms of overall snowmobile characteristics including handling, agility, unchanged stock chassis and ease of conversion from a gas to electric powertrain.

Another factor that affects the handling is weight distribution. Ideally, most of the weight has to be concentrated on top of the skis. The components needed for an electrical vehicle are often space consuming and especially since the stock chassis was not originally designed to accommodate these components, packaging becomes a considerable challenge. To facilitate the packaging and condensing most of the weight on top of the skis, an accumulator with a high volumetric energy density (VED) is desired. Table 3 demonstrates that the Lithium-ion technology is again an ideal choice.

Furthermore, the high VED offered by Lithium ion batteries facilitates an electric conversion. The motivation is that the transition from a traditional snowmobile to an electric one has to be easy, fast and reliable, which requires minimum possible changes to the stock chassis. Changing the stock chassis is design intensive as well as time and money consuming. Also, the simplicity of Wendigo’s design makes it possible to easily convert any gas snowmobile to an electric one.

### Reliability and simplicity

One of the most important aspects that have to be looked into is the potential difference that different battery chemistries provide. Based on Table 3, in order to achieve greater potentials with lead acid absorbent glass mat (Pb-acid AGM) and nickel metal hydride (NiMH), higher numbers of cells are required compared to Lithium-ion. Thus, the reduced number of cells simplifies the design by decreasing the number of interconnects, sense wires for the Battery Management System (BMS) which will lead to a simpler battery enclosure construction and assembly. All these items will ensure a more reliable product with fewer points of failure.

Based on these comparisons the team decided to use Lithium-ion battery technology. Moreover, the team has long term experience with Lithium Technology Corporation (LTC) cells and acquired useful data over the years on these cells.

After determining the preferred battery chemistry and manufacturer, the next step was to look into the design of the energy storage. Most of the available data from the LTC cells were from last year’s testing. Unfortunately, last year was the sixth year that those cells were being used; therefore the nominal value of their energy capacity was not reflective of their actual state. The energy capacity of the old LTC batteries (20 cells pack at 72 volts) first had to be determined, considering the same vehicle weight and snow condition as last year’s range competition. Data showed that the battery was being drained at 45A. Knowing that 20 cells at 72 volts could easily achieve the desired range, the team decided to look into higher voltages as well. The decision was made to discover the pros and cons of a 26 cells pack at 93.6 volts, shown in Table 4 below.

In 2012 competition, we achieved a range of 9.84 despite driving the sled at a speed higher than 32km/h. Simulation results show that with a shorter track and at 32km/h the battery pack capacity is adequate for the 10 mile range requirement.

	72 volts (20 cells)	93.6 volts (26cells)
Range	13.03 miles	16.94 miles
Weight (kg)	30	39
Cells Cost	\$6000	\$7800
Energy	3240 Wh	4214 Wh

**Table 4** – Battery pack comparison

Furthermore, loaded acceleration simulations were done using the powertrain simulation analysis toolkit (PSAT) in order to compare the performance of a 20 cell pack to a 26 cells pack, shown in Table 5.

Loaded Acceleration		
Drive Ratio	72V	93.6V
2	22.55 s	21.71 s
3	19.7 s	17.85 s
4	19.13 s	17.48 s
5	19.02 s	17.72 s
6	19.27 s	17.95 s
7	19.84 s	18.69 s

**Table 5** – Loaded acceleration time simulations

The model takes into account snow friction, aerodynamic drag and traction limits. Moreover, the simulations were performed using an 800 lbs trailer load over 500 ft. Clearly, the 93.6 volts pack is superior to the 72 volts pack excluding the weight and MSRP events. At this point, the question was whether or not the consumer would be willing to pay considerably more for slightly higher performances.

Among the two qualities that are increased by the 93.6 volts pack, range has the

highest actual and perceived value. Acceleration is not as important as range in North and South Pole. In order to find out the need of the target audience, the results from the last snowmobile (Wisconsin – Madison Clean Snowmobile team) that was tested in Greenland was analyzed. The following paragraph is a summary (from the 2011 CSC report) of their range tests in Greenland. “During an extensively studied 10 day period in July, there were 72 trips during which the sled moved more than 0.16 km (0.1 mi), 47 were over 0.8 km (0.5 mi), 14 were over 1.6 km (1 mi), 6 were over 3.2 km (2 mi), and 3 were over 4.8 km (3 mi).

In total, the vehicle traveled 341 km (212 mi) during the 57 days it was operational at Summit in the 2008 summer season, an average of 6.0 km (3.7 mi) per day. The sled was in motion for 25.9 hours, with an average speed of 13 km/hr (8 mph).” They added “Initial experiences in Greenland show that the BuckEV could tow a 1500 lb payload five to ten miles before needing to be recharged. The loaded range is substantially lower than that measured in the competition range event, typically by a factor of 2-3, depending on conditions and load, suggesting that a minimum unloaded range of 20-30 miles is necessary to reliably achieve a ten mile useable range<sup>3</sup>.”

This report shows that the distance travelled while pulling a heavy load was two to three times less than the equivalent distance travelled by unloaded snowmobile. Hence, the unloaded snowmobile should travel at least 18 km (11.1mi) and both 72V and 93.6V battery packs are able to travel this distance.

All in all, these results demonstrate that the 72 volts pack will be more than sufficient for the scientists in the North and South Poles and the extra money spent on the 93.6V pack does not significantly improve the sled’s performances. Moreover, a bigger battery pack would require using more space and increase the

mass of the snowmobile by 30%, which causes problems in the area of packaging, agility and handling.

It is important to remember that best mentioned battery technology mentioned in this paper (Li-ion) has a GED of 240 Wh/kg which is 54 times less than the gasoline's GED (13000 Wh/kg). Due to this energy density difference, it is not possible to build a proper sized snowmobile with a significant range.

Figure 2 illustrates the final design of the 2012 accumulator box.



**Figure 2** – 2012 Battery box design

**POWERTRAIN**

The electric drivetrain consists of a three phase AC induction motor with a peak power output of 25 kW. The motor controller is a Curtis Instruments 1238 with 48-80V range and maximum current of 550<sub>rms</sub>.

In the past, McGill electric snowmobiles have used permanent magnet, brushed DC motors. Although these motors have excellent power density, the team has experienced carbon dust collection inside the motor which can eventually lead to a connection between the high voltage circuit and body of the motor and hence the vehicle chassis. The ground fault detector would detect such problem and cut off power to the vehicle, so although there is no danger to the driver the carbon dust accumulation leads to an

element of unreliability. The AC induction motor reduces the maintenance costs, improves safety and reliability while delivering constant power at high efficiency over wide speed range.

Dynamometer testing showed that this motor could exceed the current limits of the batteries, so it was necessary to implement a power limiting map to avoid damaging the batteries. Graphs 1 and 2 show the comparison between the 1236 and 1238 controllers tested at different current limits. The 180A and 300A current limit corresponds to gauge 2 and 2/0 wire fuse requirements.

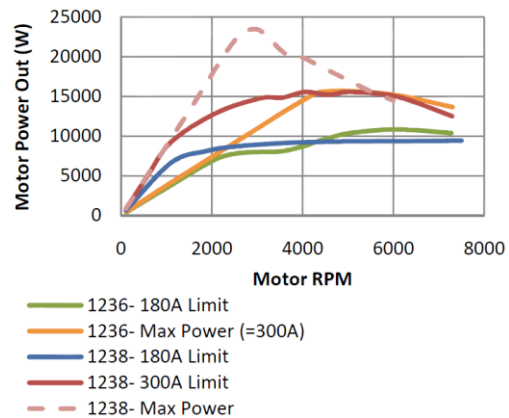

**Graph 1** – Motor power output versus RPM

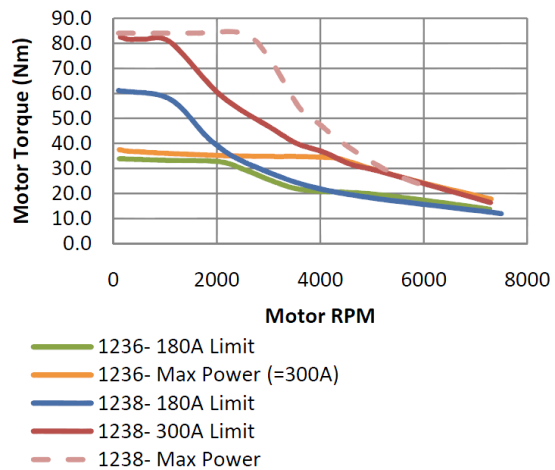

**Graph 2** – Motor torque versus RPM

The Curtis Instruments motor controllers are highly customizable. For the different current limits tested, the controllers were fine-tuned by adjusting system parameters such as slip-gain to maximize low torque. Maximizing low-end torque is a logical choice for an electric snowmobile because of the gains possible in the CSC scoring scheme and for towing heavy equipment on the Greenland Ice Cap. Graph 3 shows how much the torque curve varies with the slip-gain parameter for the 1238 controller. For both current limit maps peak low-end torque gain of approximately 15% was achieved over a range of range 2000 rpm.

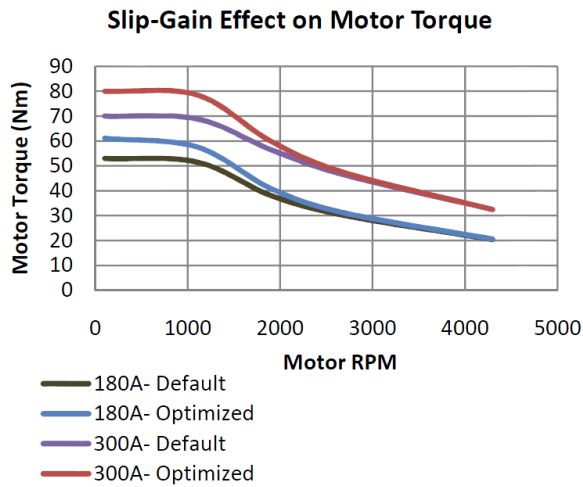

**Graph 3 – Motor torque versus RPM**

In order to determine the final drive ratio, the dynamometer data was used to build a snowmobile model into PSAT. Using coast downs, the total drag forces acting against the snowmobile at different speeds were determined, which helped to reach high levels of simulation accuracy. The simulation objective was to determine the drive ratio that offers the best compromise between acceleration and efficiency at 32 km/h which is the endurance event speed. The following table shows PSAT results for 300A current limit on 1238 controller.

Drive Ratio	2	3	4	5	6
100m	9.6	8.8	8.5	8.6	9.3
500ft loaded acceleration	22.6	19.7	19.1	19.0	19.3
Motor RPM at 32 km/h	1850	2800	3700	4600	5550

**Table 6 – Drive ratio optimization**

The motor delivers power at peak efficiency of around 80% in the range of 3000 – 6000 RPM, as shown on Graph 4 below.

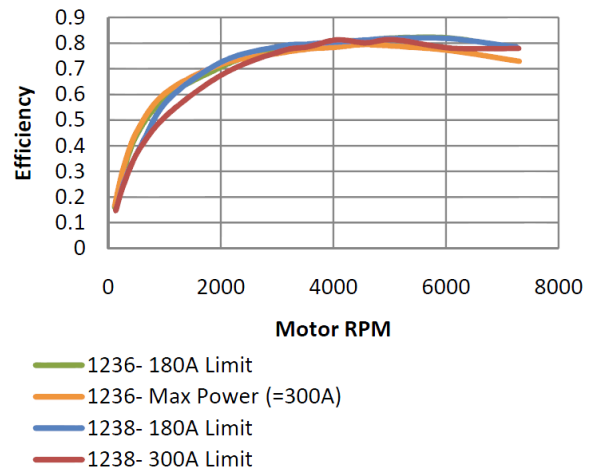

**Graph 4 – Motor efficiency versus RPM**

At 32 km/h, a drive ratio of 3 or higher will have the motor operating at its peak efficiency. The snowmobile’s chaincase has a maximum gear ratio of 3, so a secondary gear reduction is required to achieve a ratio greater than 3. A secondary ratio would reduce the overall drivetrain efficiency (belt drive is around 95% efficient) as well as limit space in the engine bay for batteries. At a final drive of 3, the motor will operate near 3000 RPM at 32km/h with efficiency close to the peak efficiency of 80%. Therefore, the AC induction motor is directly coupled to the chain drive resulting in final ratio of 3:1. This choice simplifies the drivetrain design while providing better performance and efficiency.



Furthermore, the performance of a sled in the draw bar pull event depends on the amount of force it can transmit to the ground within the traction limit. This implies that the higher the motor output torque, the better the sled can perform as long as traction is available. The slip-gain optimized 1238 controller at 300A limit delivers maximum torque which makes it the best choice for draw bar pull and loaded acceleration events.

	Year	McGill University				
		Total Mass	Rear Mass	Pull Force	Total Mass + 75kg Force ratio	Rear + 60 kg Force ratio
		Kg	Kg	N	N/Kg	N/Kg
1	2007	227	91	1660	5	11
2	2008	263	158	1867	6	9
3	2009	226	100	1759	6	11
4	2010	233	110	2870	9	17
5	2011	233	109	2113	7	12
	<b>AVG</b>	<b>236</b>	<b>114</b>	<b>2054</b>	<b>7</b>	<b>12</b>

### DRAW BAR PULL ANALYSIS

For this year’s competition, particular attention was put on improving the towing capabilities of our sled, considering the fact that the snowmobile towing capacity is limited by traction rather than motor torque. Researchers and scientists at Summit Station are often required to tow heavy equipment such as scientific apparatus, thus our team decided to put resources into optimizing the existing hitch structure. Confident that a simple design could possibly lead to significant towing improvements, the team decided to go forward with the project.

By comparing the track specifications of last year’s sled (BRP Tundra 2006) to this year’s snowmobile (BRP Tundra LT 2011), one can tell that the LT has superior traction capabilities due to its larger, longer and more profiled track (154x16x1.5” versus 136x15x0.75”). More specifically, an analysis of previous year’s results for the draw bar pull event allowed the team to correlate the ratio of the pulling force to the applied weight, shown in Table 7.

**Table 7** – Pull force to weight analysis based on previous year’s results.

These results are based on the assumption that the driver’s weight front-rear distribution is 20-80%. Moreover, one should note that in 2010, the draw bar pull was done on grass, explaining the higher forces. Interestingly, the team found out that for each kilogram of weight added on the rear suspension, the pulling force was increased by 12 N. Therefore, in order to significantly increase the sled’s towing capabilities, the team had to engineer a system that would maximise weight at the rear of the snowmobile.

After brainstorming on different designs, and realizing that manufacturing opportunities were limited, the team opted for a relatively simple design that consisted of building an elevated rear module on which the hitch would be mounted on. By putting the attachment point higher, the vertical component of the pulling force increases and thus allows for greater traction. Although that design theoretically works, the team had to quantify the pulling force benefit to determine if it was worth building it. The approach consisted of determining the geometry of the buggy, and to approximate specific distances in order to determine the new angle of the rope,  $\Phi_2$ , shown in Figure 3.

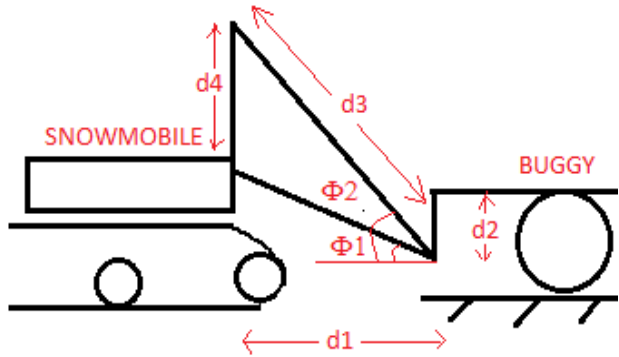

**Figure 3** – Buggy geometry with rear module.

- d1 = 6'
- d2= 6.3''
- d3= 6' (calculated)
- d4= 10.5''
- Φ1=5°
- Φ2=13° (calculated)

After having determined the geometry of the new design, quantitative assessments were conducted based on previous years pulling forces, shown in Table 8 below.

	<u>Year</u>	<u>Pull Force</u>
		<u>N</u>
1	2007	1660
2	2008	1867
3	2009	1759
4	2010	2870
5	2011	2113
	<b>AVG</b>	<b>2054</b>

**Table 8-** McGill University draw bar pull results.

Based on the assumption that the pulling force is measured along the axis of the rope, it was found that the average pulling force was 2054 N, and knowing the rope angle of both last year and this year designs, one could conduct a force analysis, shown in Figure 4. Note that the X-component remains the same in both designs; however, the Y-component, the pulling force, P and the angles change.

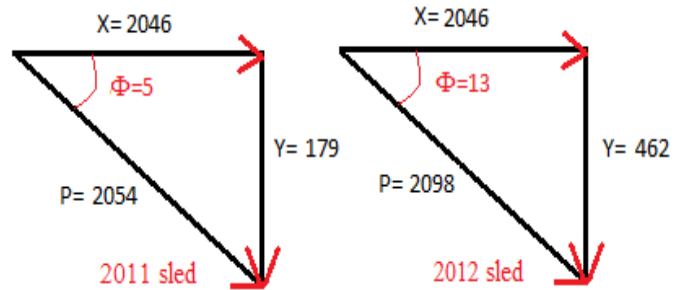
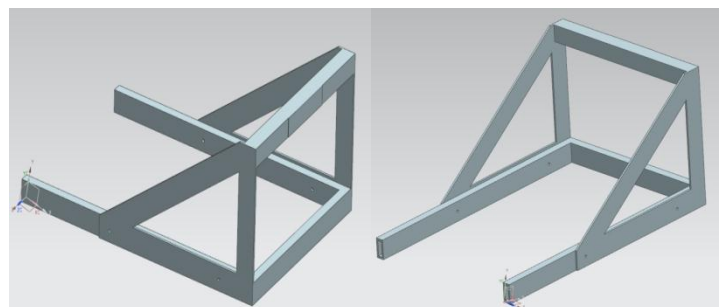

**Figure 4-** Pulling force components breakdown (in Newtons).

Analysis of Figure 4 shows the pulling force increase,  $\Delta P = 44 \text{ N}$ , and  $\Delta Y = 283 \text{ N}$ . Moreover, based on our previous analysis, it was shown that the ratio of pulling force to weight is 12N/kg. Therefore, one must factor the increase in Y-component to accurately measure the new pulling force,  $\Delta P$ . From our calculations,  $\Delta Y = 283 \text{ N} = 29 \text{ kg}$ , and thus the increase in pulling force from the additional vertical weight equals to:

$$12 \text{ N/kg} * 29 \text{ kg} = 348 \text{ N}$$

From this, one can calculate the new pulling force, which equals to 2446 N. Comparison with last year's design shows an increase of **392 N** (+88 lbs), which is quite significant. Figure 5 illustrates 3D renderings of the hitch module design.



**Figure 5** – 2012 Hitch design using NX Unigraphics 7.5



## NOISE ATTENUATION

Noise produced by snowmobiles is a major issue in rural areas where snowmobiles are driven. The noise emitted is disruptive to both wildlife and people who inhabit the area surrounding snowmobile trails. Since the muffler is responsible for much of the noise produced, zero emission snowmobiles generate far less noise than their internal combustion counterparts. For a snowmobile, any decrease in noise is beneficial for the environment, people who live close to trails and the snowmobile user. It can also advance safety; one major issue for alpine search and rescue teams is the danger of causing a secondary avalanche. A low noise snowmobile would greatly reduce the likelihood of inducing an avalanche, and would therefore be ideal for this application.

Noise reduction in most mechanical systems is broken down into four categories: structural, isolation, cancellation and localized. Based on cost and feasibility, structural, isolation and localized noise attenuation techniques were the centers of focus of noise reduction on Wendigo. Cancellation techniques would require an actuator which is constantly being tuned to cancel the sources of vibration which would be difficult and prohibitively expensive to implement.

Structural noise reduction involves the addition of supports on membranes, which create noise when vibrated – similar to the way a subwoofer produces noise by displacing air. Increased support at areas which vibrate the most will dissipate energy and reduce the total noise.

Localized noise reduction involves reducing system to system vibration transmission. Placing damping material between a source of vibration, like the motor or any moving part, causes the dampener to absorb

vibrational energy and prevents its transmission to areas where it will amplify the noise like a free membrane.

Moreover, in order to prevent sound from being transmitted to the observer, isolation noise reduction utilizes a physical barrier placed between the source and the listener. The sound waves are then dissipated into the barrier and mechanism.

Testing was performed to determine the most effective means of reducing noise produced by our snowmobile. Before testing any of the techniques, information was gleaned from previous years' competition data. A spectral analysis of McGill and other schools' past sound files yielded interesting results. Both the internal combustion and the zero emission snowmobiles produced the highest amplitude of noise at approximately 110 Hz, shown in Figure 6. The spectral analyses of previous years' competitions also showed smaller peaks around 300 Hz and ones around 600 Hz.

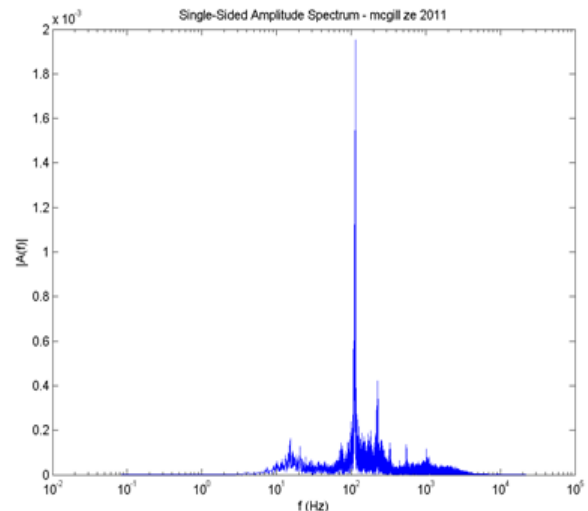

**Figure 6** - Spectral Analysis of MEST's 2011 Sound Results

Since the 110 Hz frequency was common to both internal combustion and electric snowmobiles, it was likely structural. It was also found not to be the frequency at which the motor was running and so was not due to a forcing frequency. It was determined that the most likely source of this noise was the snowmobile chassis, and so it became the primary focus of the noise attenuation efforts. Finite element analysis of a previous year's chassis indicated that at resonance frequencies bending at the tips of the foot rests tended to be a major hotspot of vibration, shown in Figure 7. In order to confirm these results, the chassis was vibrated using a variable speed miniature motor. An accelerometer was mounted at various spots around the chassis to map out the vibration in terms of maximum displacement. The results confirmed that the tips of the foot rests had a significant displacement, but also showed a great deal of displacement at certain points along the center of the chassis. However, the vibration at the center is likely dampened by the seat and the driver's weight.

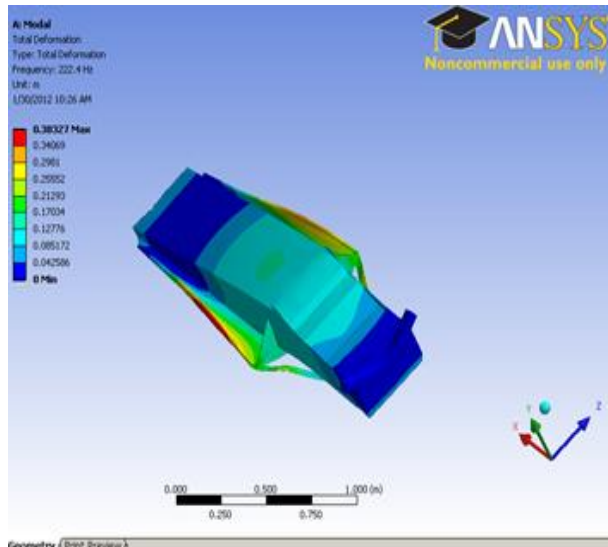

**Figure 7 - Deformation of Snowmobile Chassis at First Mode**

In order to structurally modify the snowmobile, three dampening products were

considered: dampening viscoelastic pads, viscoelastic gel and structural supports. After considering different products, Second Skin's Damplifier pads and Spectrum Coating were selected based on their cost and the availability of vendors. As for supports, simple L-brackets were considered.

The Damplifier pads and Spectrum Coating were tested for efficacy. Two identical halves from an aluminum gas tank were attached to an electric vibrator, shown in Figure 8 below. Decibel readings were taken as they vibrated; first hanging unmodified, then with adhered Damplifier pads or painted on Spectrum Coating, as shown in Figure 9.



**Figure 8 - Vibrator Setup**

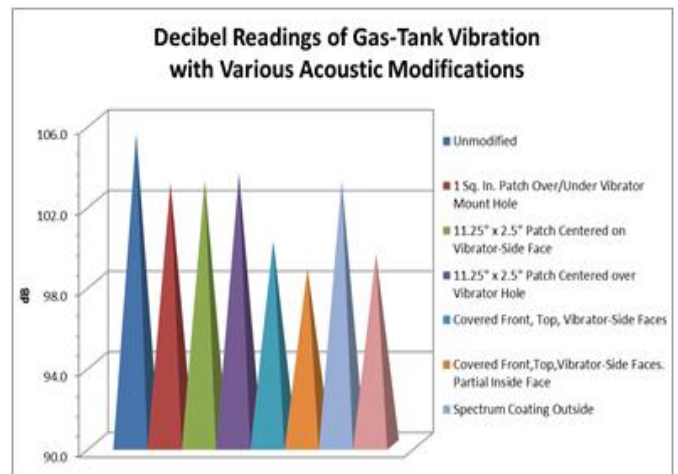

**Figure 9 - Decibel Reading Results for Various Modifications**

Results showed that both products had a noticeable effect. However, the Damplifier pads were more effective, reducing the noise by roughly 6.5 dB, and resulted in less additional weight. Based on these two criteria it was determined that the Damplifier pads were a superior product than the Spectrum Coating. The experiment also showed that even a small section of Damplifier pads placed between the tank and the vibrator caused a noticeable reduction. A square inch section of Damplifier pads placed on either side of the mounting point of the vibrator reduced the noise level by roughly 2.5 dB. This result reinforced the need to employ localized reduction techniques by installing some sort of dampener between the snowmobile and sources of vibration.

Once the Spectrum Coating was ruled out, the bare chassis that underwent finite element modelling was vibrated again to determine whether structural supports or Damplifier pads were more effective. Supports were bolted to the outside corner of the foot rest and the vertical portion of the chassis. An L shaped beam was installed perpendicular to the length of the chassis at the spot of greatest deformation. Afterwards, the brackets and beam were removed and Damplifier pads were adhered to the areas which vibrated the most. Again Damplifier pads had the most effect in terms of vibration and noise level. Graph 5 shows the reduction of acceleration at a point on the chassis that had been covered by a Damplifier pad.

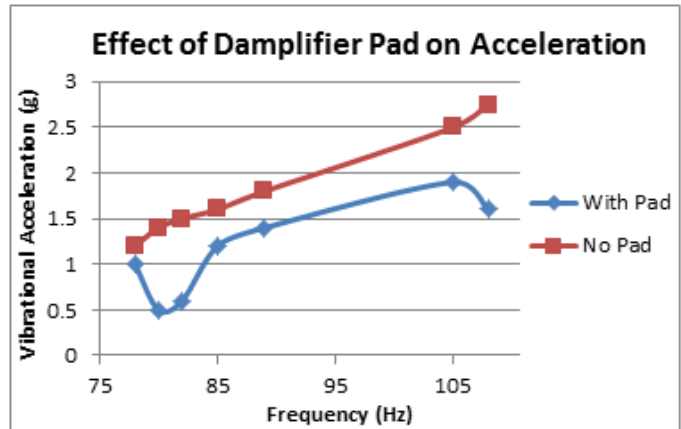

Graph 5 – Effect of Damplifier Pads on Local Acceleration on the Bare Chassis

In some cases the supports actually increased the noise; it is believed this was caused because the supports were bolted to the chassis, and it is expected that better results would be achieved if the supports were welded. However, welding would be irreversible, and the team decided not to go forward with that idea.

The question remained whether or not it would be better to simply have the Damplifier pads at the hotspots of vibration or to have them cover as much as possible. The chassis was vibrated and the accelerometer data proved that adding more Damplifier pads, even at spots of low vibration, caused a reduction in the overall deformation of the chassis.

Testing provided the framework for a noise attenuation strategy. Simple noise reduction techniques commonly used in mechanical systems were also incorporated.

- Damplifier pads would be placed between components bolted to the chassis.
- Damplifier pads would cover the foot rests and walls of the chassis.

- Loose plastic components which comprise the hood would have foam lining along where they touch to prevent rattling.
- Loose wires would be taped down.
- Openings at the front would be closed off to isolate sound resonating from under the hood (isolation).



**Figure 10** - Motor Mounting Point Before adding Damplifier Pad



**Figure 11** - Motor Mounting Point after adding Damplifier pads

In terms of cost, Damplifier pads are relatively cheap at roughly \$55 for every 10 square feet so the implementation of such materials in snowmobiles is interesting. Furthermore, the only safety concern in modifying the snowmobile is in blocking the air vents at the front of the snowmobile. With an internal combustion engine, keeping the engine from overheating is paramount. An electric

snowmobile does not have the same need for cooling. However, the completed snowmobile was observed closely to ensure that it did not overheat because of the blocked vents.

To ensure the reliability of such pads in cold climates, the Damplifier pads were attached to the gas tank and left outside in -15°C weather for two hours to test its adherence abilities. It succeeded in remaining stuck on the gas tank. Its ability to dampen was hindered slightly by the lower temperature but not significantly.

## **ADDITIONAL FEATURES**

The 2012 Wendigo prototype offers different interesting features which make the sled highly polyvalent, including:

### **CAN communication**

CAN is a standard messaging system that is standardized in vehicle industry. The snowmobile's batteries and motor controller, capable of CAN communication, enable the user to monitor vehicle's parameters such as, voltage, state of charge, vehicle speed, battery current and temperature. It also helps the user to troubleshoot the vehicle by alerting them with error messages whenever a problem occurs.

### **Reverse**

The snowmobile is equipped with a reverse switch that enables the drivers to conveniently maneuver the snowmobile.

## **CONCLUSION**

MEST fundamental design goal was to produce a reliable and affordable electric snowmobile which is easy to convert from a gasoline machine. More specifically, the objectives were to enhance the towing capacity

of the sled, to reduce noise at the source, to increase the power output as well as to increase range. Based on this year's design and analysis, the team expects to increase its towing capacity by 88 lbs, to have a noise level below 57 dB, to increase power by 50% and to increase range by 40%.

## **ACKNOWLEDGMENTS**

The McGill Electric Snowmobile Team would like to thank everyone who made the 2013 Wendigo prototype possible. A special thanks for our advisor, Peter Radziszewski, and the technical staff at McGill University. Lastly, the team would like to thank its partners and sponsors:

McGill Faculty of Engineering, UGS, McGill EUS, National Instruments, SSMU.

## **REFERENCES**

1. Snowmobile.com, <http://www.snowmobile.com/manufacturers/ski-doo/2012-fancooled-budget-snowmobiles-1484.html>, accessed on 02-22-2013.
2. ICCNexergy, <http://iccnexergy.com/battery-chemistry-comparison-chart/>, accessed on 02-20-2012.
3. Spannbauer S, et al., "Implementation of a Battery Management System into a Lithium-Ion Battery Suitable for Arctic Environments in a Zero-Emissions Sled", University of Wisconsin-Madison, 2011